

Micro-Power, Rail-to-Rail CMOS Comparators with Push-Pull/Open-Drain Outputs and TinyPak Package

General Description

The LMC7215/LMC7215-Q1/LMC7225 are ultra low power comparators with a maximum of 1 μA power supply current. They are designed to operate over a wide range of supply voltages, from 2V to 8V.

The LMC7215/LMC7215-Q1/LMC7225 have a greater than rail-to-rail common mode voltage range. This is a real advantage in single supply applications.

The LMC7215 features a push-pull output stage. This feature allows operation with absolute minimum amount of power consumption when driving any load.

The LMC7225 features an open drain output. By connecting an external resistor, the output of the comparator can be used as a level shifter to any desired voltage to as high as 15V.

The LMC7215/LMC7215-Q1/LMC7225 are designed for systems where low power consumption is the critical parameter. Guaranteed operation over the full supply voltage range of 2.7V to 5V and rail-to-rail performance makes this comparator ideal for battery-powered applications.

Features

(Typical unless otherwise noted)

- Ultra low power consumption 0.7 μA
- Wide range of supply voltages 2V to 8V
- Input common-mode range beyond V^+ and V^-
- Open collector and push-pull output
- High output current drive: (@ $V_S = 5\text{V}$) 45 mA
- Propagation delay (@ $V_S = 5\text{V}$, 10 mV overdrive) 25 μs
- Tiny 5-Pin SOT23 package
- Latch-up resistance >300 mA
- LMC7215-Q1 is an Automotive Grade product that is AEC-Q100 grade 3 qualified.

Applications

- Laptop computers
- Mobile phones
- Metering systems
- Hand-held electronics
- RC timers
- Alarm and monitoring circuits
- Window comparators, multivibrators
- Automotive

Connection Diagrams

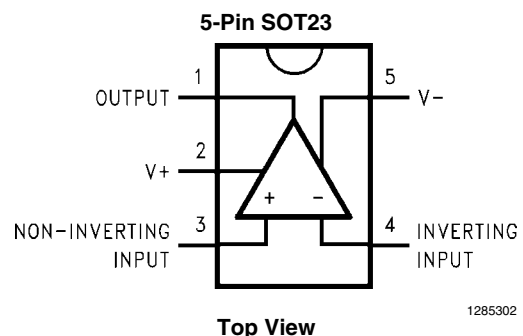
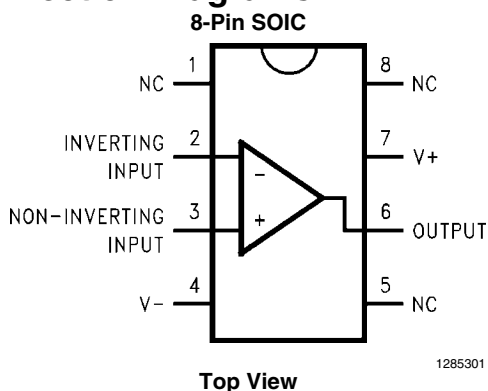

Absolute Maximum Ratings *(Note 1)*

If Military/Aerospace specified devices are required, please contact the Texas Instruments Sales Office/ Distributors for availability and specifications.

ESD Tolerance <i>(Note 2)</i>	2 kV
Differential Input Voltage	V+ +0.3V, V- -0.3V
Voltage at Input/Output Pin	V+ +0.3V, V- -0.3V
Supply Voltage (V+–V-)	10V
Current at Input Pin	±5 mA
Current at Output Pin <i>(Note 3)</i>	±30 mA
Current at Power Supply Pin	40 mA

Lead Temperature (soldering, 10 sec)	260°C
Storage Temperature Range	-65°C to +150°C
Junction Temperature <i>(Note 4)</i>	150°C

Operating Ratings *(Note 1)*

Supply Voltage	$2V \leq V_{CC} \leq 8V$
Temperature Range <i>(Note 4)</i>	-40°C to +85°C
Package Thermal Resistance (θ_{JA})	
8-Pin SOIC	165°C/W
5-Pin SOT23	325°C/W

2.7V to 5V Electrical Characteristics

Unless otherwise specified, all limits guaranteed for $T_J = 25^\circ\text{C}$, $V_+ = 2.7\text{V}$ to 5V , $V_- = 0\text{V}$, $V_{CM} = V_O = V_+/2$. **Boldface** limits apply at the temperature extremes.

Symbol	Parameter	Conditions	Typ <i>(Note 5)</i>	LMC7215 Limit <i>(Note 6)</i>	LMC7225 Limit <i>(Note 6)</i>	Units
V_{OS}	Input Offset Voltage		1	6	6	mV
				8	8	max
TCV_{OS}	Input Offset Voltage Average Drift		2			$\mu\text{V}/^\circ\text{C}$
I_B	Input Current		5			fA
I_{OS}	Input Offset Current		1			fA
CMRR	Common Mode Rejection Ratio	<i>(Note 7)</i>	80	60	60	dB
				min		
PSRR	Power Supply Rejection Ratio	$V_+ = 2.2\text{V}$ to 8V	90	60	60	dB
						min
A_V	Voltage Gain		140			dB
CMVR	Input Common-Mode Voltage Range	$V_+ = 2.7\text{V}$	3.0	2.9	2.9	V
		CMRR > 50 dB		2.7	2.7	min
		$V_+ = 2.7\text{V}$	-0.2	0.0	0.0	V
		CMRR > 50 dB		0.2	0.2	max
		$V_+ = 5.0\text{V}$	5.3	5.2	5.2	V
		CMRR > 50 dB		5.0	5.0	min
		$V_+ = 5.0\text{V}$	-0.3	-0.2	-0.2	V
		CMRR > 50 dB		0.0	0.0	max

Symbol	Parameter	Conditions	Typ (Note 5)	LMC7215 Limit (Note 6)	LMC7225 Limit (Note 6)	Units
V _{OH}	Output Voltage High	V ⁺ = 2.2V I _{OH} = 1.5 mA	2.05	1.8 1.7	NA	V min
		V ⁺ = 2.7V I _{OH} = 2.0 mA	2.05	2.3 2.2	NA	V min
		V ⁺ = 5.0V I _{OH} = 4.0 mA	4.8	4.6 4.5	NA	V min
V _{OL}	Output Voltage Low	V ⁺ = 2.2V I _{OH} = 1.5 mA	0.17	0.4 0.5	0.4 0.5	V max
		V ⁺ = 2.7V I _{OH} = 2.0 mA	0.17	0.4 0.5	0.4 0.5	V max
		V ⁺ = 5.0V I _{OH} = 4.0 mA	0.2	0.4 0.5	0.4 0.5	V max
I _{SC+}	Output Short Circuit Current (Note 10)	V ⁺ = 2.7V, Sourcing	15		NA	mA
		V ⁺ = 5.0V, Sourcing	50		NA	mA
I _{SC-}	Output Short Circuit Current (Note 10)	V ⁺ = 2.7V, Sinking	12			mA
		V ⁺ = 5.0V, Sinking	30			mA
I _{Leakage}	Output Leakage Current	V ⁺ = 2.2V V _{IN+} = 0.1V, V _{IN-} = 0V, V _{OUT} = 15V	0.01	NA	500	nA max
I _S	Supply Current	V ⁺ = 5.0V	0.7	1 1.2	1 1.2	μA max
		V _{IN+} = 5V, V _{IN-} = 0V				

AC Electrical Characteristics

Unless otherwise specified, T_J = 25°C, V⁺ = 5V, V⁻ = 0V, V_{CM} = V⁺/2

Symbol	Parameter	Conditions	LMC7215 Typ (Note 5)	LMC7225 Typ (Note 5, Note 8)	Units	
t _{rise}	Rise Time	Overdrive = 10 mV (Note 8)	1	12.2	μs	
t _{fall}	Fall Time	Overdrive = 10 mV (Note 8)	0.4	0.35	μs	
t _{PHL}	Propagation Delay (High to Low)	(Note 8, Note 9)	Overdrive = 10 mV	24	24	μs
			Overdrive = 100 mV	12	12	
		V ⁺ = 2.7V (Note 8, Note 9)	Overdrive = 10 mV	17	17	μs
			Overdrive = 100 mV	11	11	
t _{PLH}	Propagation Delay (Low to High)	(Note 8, Note 9)	Overdrive = 10 mV	24	29	μs
			Overdrive = 100 mV	12	17	
		V ⁺ = 2.7V (Note 8, Note 9)	Overdrive = 10 mV	17	22	μs
			Overdrive = 100 mV	11	16	

Note 1: Absolute Maximum Ratings indicate limits beyond which damage to the device may occur. Operating Ratings indicate conditions for which the device is intended to be functional, but specific performance is not guaranteed. For guaranteed specifications and the test conditions, see the Electrical Characteristics.

Note 2: Human Body Model, applicable std. MIL-STD-883, Method 3015.7. Machine Model, applicable std. JESD22-A115-A (ESD MM std. of JEDEC) Field-Induced Charge-Device Model, applicable std. JESD22-C101-C (ESD FICDM std. of JEDEC).

Note 3: Applies to both single-supply and split-supply operation. Continuous short circuit operation at elevated ambient temperature can result in exceeding the maximum allowed junction temperature of 150°C.

Note 4: The maximum power dissipation is a function of $T_{J(MAX)}$, θ_{JA} , and T_A . The maximum allowable power dissipation at any ambient temperature is $P_D = (T_{J(MAX)} - T_A)/\theta_{JA}$. All numbers apply for packages soldered directly into a PC board.

Note 5: Typical values represent the most likely parametric norm as determined at the time of characterization. Actual typical values may vary over time and will also depend on the application and configuration. The typical values are not tested and are not guaranteed on shipped production material.

Note 6: All limits are guaranteed by testing or statistical analysis.

Note 7: CMRR measured at $V_{CM} = 0V$ to 2.5V and 2.5V to 5V when $V_S = 5V$, $V_{CM} = 0.2V$ to 1.35V and 1.35V to 2.7V when $V_S = 2.7V$. This eliminates units that have large V_{OS} at the V_{CM} extremes and low or opposite V_{OS} at $V_{CM} = V_S/2$.

Note 8: All measurements made at 10 kHz. A 100 k Ω pull-up resistor was used when measuring the LMC7225. $C_{LOAD} = 50$ pF including the test jig and scope probe. The rise times of the LMC7225 are a function of the R-C time constant.

Note 9: Input step voltage for the propagation measurements is 100 mV.

Note 10: Do not short the output of the LMC7225 to voltages greater than 10V or damage may occur.

Typical Performance Characteristics $T_A = 25^\circ\text{C}$ unless otherwise specified

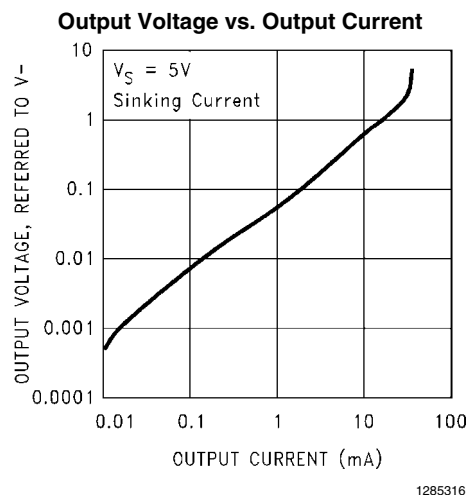
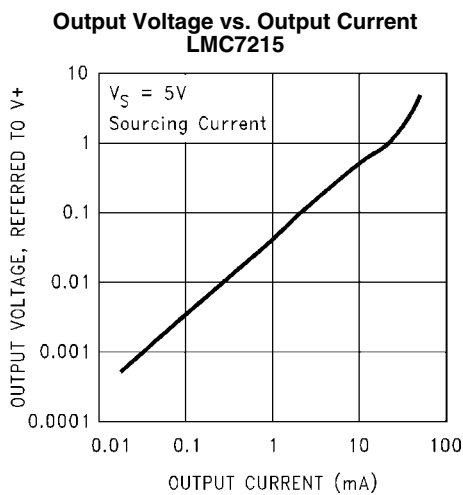
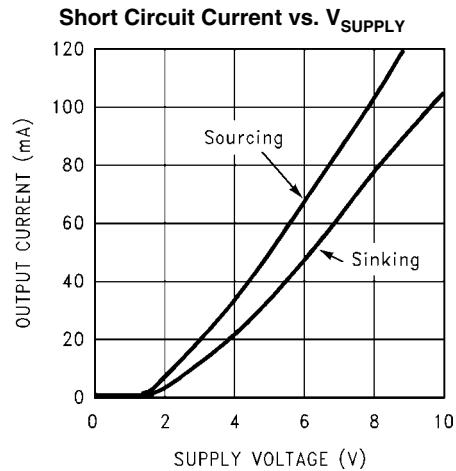
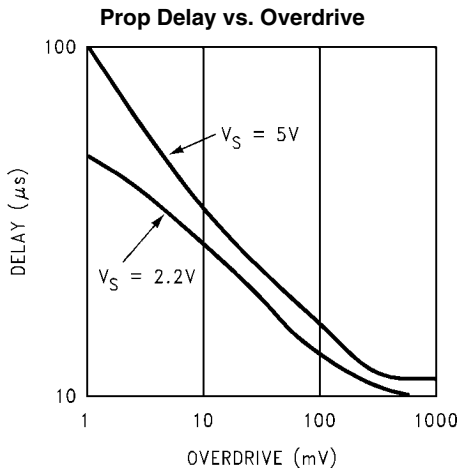
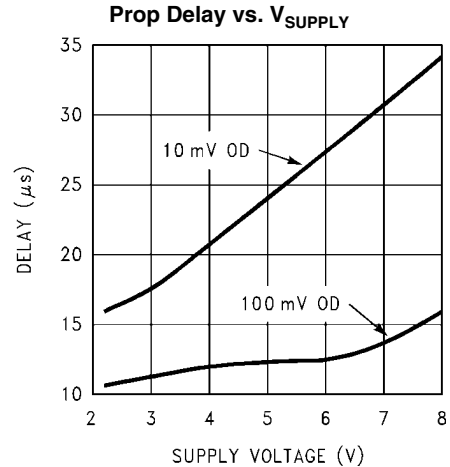
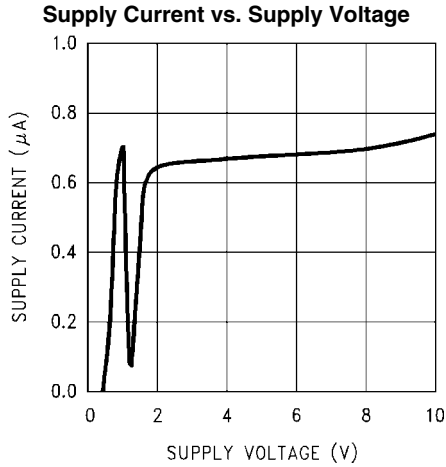

**Output Voltage vs. Output Current
LMC7215**

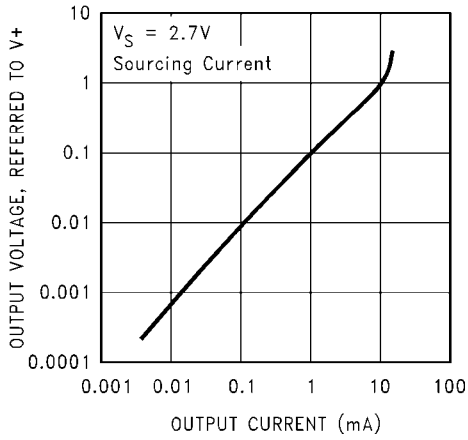

1285317

Output Voltage vs. Output Current

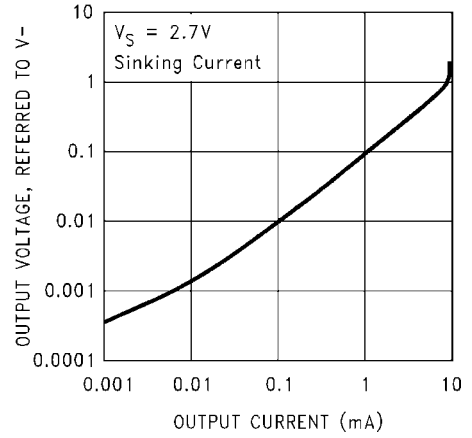

1285318

**Output Leakage Current vs. Output Voltage
LMC7225**

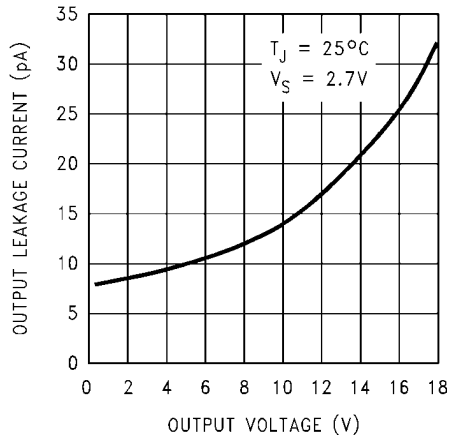

1285319

**Output Leakage Current vs. Output Voltage
LMC7225**

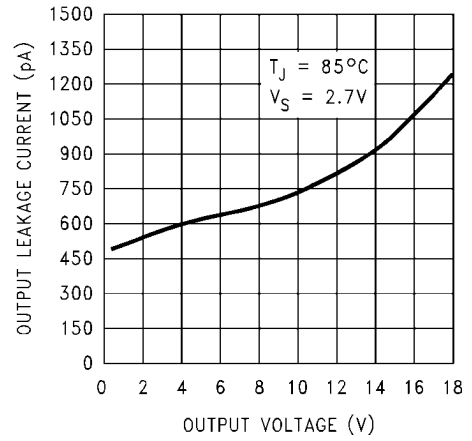

1285320

Application Information

RESPONSE TIME

Depending upon the amount of overdrive, the delay will typically be between 10 μs to 200 μs . The curve showing delay vs. overdrive in the “Typical Characteristics” section shows the delay time when the input is preset with 100 mV across the inputs and then is driven the other way by 1 mV to 500 mV.

The transition from high to low or low to high is fast. Typically 1 μs rise and 400 ns fall.

With a small signal input, the comparators will provide a square wave output from sine wave inputs at frequencies as high as 25 kHz. *Figure 1* shows a worst case example where a ± 5 mV sine wave is applied to the input. Note that the output is delayed by almost 180°.

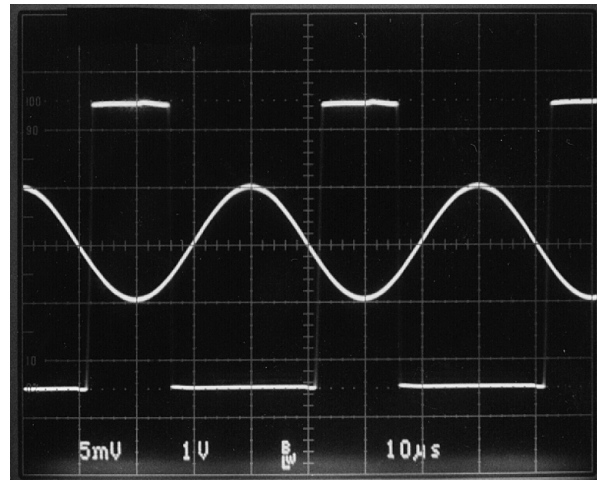

1285304

FIGURE 1.

NOISE

Most comparators have rather low gain. This allows the output to spend time between high and low when the input signal changes slowly. The result is the output may oscillate between high and low when the differential input is near zero.

The exceptionally high gain of these comparators, 10,000 V/mV, eliminates this problem. Less than 1 μV of change on the input will drive the output from one rail to the other rail.

If the input signal is noisy, the output cannot ignore the noise unless some hysteresis is provided by positive feedback.

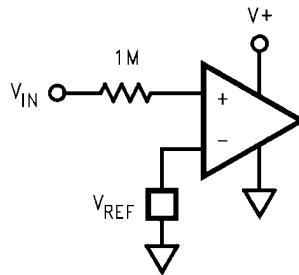

1285305

FIGURE 2.

INPUT VOLTAGE RANGE

The LMC7215/25 have input voltage ranges that are larger than the supply voltage guarantees that signals from other parts of the system cannot overdrive the inputs. This allows sensing supply current by connecting one input directly to the V+ line and the other to the other side of a current sense resistor. The same is true if the sense resistor is in the ground return line.

Sensing supply voltage is also easy by connecting one input directly to the supply.

The inputs of these comparators are protected by diodes to both supplies. This protects the inputs from both ESD as well as signals that greatly exceed the supply voltages. As a result, current will flow through these forward biased diodes whenever the input voltage is more than a few hundred millivolts larger than the supplies. Until this occurs, there is essentially no input current. As a result, placing a large resistor in series with any input that may be exposed to large voltages, will limit the input current but have no other noticeable effect.

If the input current is limited to less than 5 mA by a series resistor, (see [Figure 2](#)), a threshold or zero crossing detector, that works with inputs from as low as a few millivolts to as high as 5,000V, is made with only one resistor and the comparator.

INPUTS

As mentioned above, these comparators have near zero input current. This allows very high resistance circuits to be used without any concern for matching input resistances. This also allows the use of very small capacitors in R-C type timing circuits. This reduces the cost of the capacitors and amount of board space used.

CAPACITIVE LOADS

The high output current drive allows large capacitive loads with little effect. Capacitive loads as large as 10,000 pF have no effect upon delay and only slow the transition by about 3 μ s.

OUTPUT CURRENT

Even though these comparators use less than 1 μ A supply current, the outputs are able to drive very large currents.

The LMC7215 can source up to 50 mA when operated on a 5V supply. Both the LMC7215 and LMC7225 can sink over 20 mA. (See the graph of Max I_O vs. V_{SUPPLY} in the "Typical Characteristics" section.)

This large current handling ability allows driving heavy loads directly. LEDs, beepers and other loads can be driven easily.

The push-pull output stage of the LMC7215 is a very important feature. This keeps the total system power consumption to the absolute minimum. The only current consumed is the less than 1 μ A supply current and the current going directly into the load. No power is wasted in a pull-up resistor when the output is low. The LMC7225 is only recommended where a level shifting function from one logic level to another is desired, where the LMC7225 is being used as a drop-in lower power replacement for an older comparator or in circuits where more than one output will be paralleled.

POWER DISSIPATION

The large output current ability makes it possible to exceed the maximum operating junction temperature of 85°C and possibly even the absolute maximum junction temperature of 150°C.

The thermal resistance of the 8-pin SOIC package is 165°C/W. Shorting the output to ground with a 2.7V supply will only result in about 5°C rise above ambient.

The thermal resistance of the much smaller 5-Pin SOT23 package is 325°C/W. With a 2.7V supply, the raise is only 10.5°C but if the supply is 5V and the short circuit current is 50 mA, this will cause a raise of 41°C in the 8-Pin SOIC and 81°C in the 5-Pin SOT23. This should be kept in mind if driving very low resistance loads.

SHOOT-THROUGH

Shoot-through is a common occurrence on digital circuits and comparators where there is a push-pull output stage. This occurs when a signal is applied at the same time to both the N-channel and P-channel output transistors to turn one off and turn the other on. (See [Figure 3](#).) If one of the output devices responds slightly faster than the other, the fast one can be turned on before the other has turned off. For a very short time, this allows supply current to flow directly through both output transistors. The result is a short spike of current drawn from the supply.

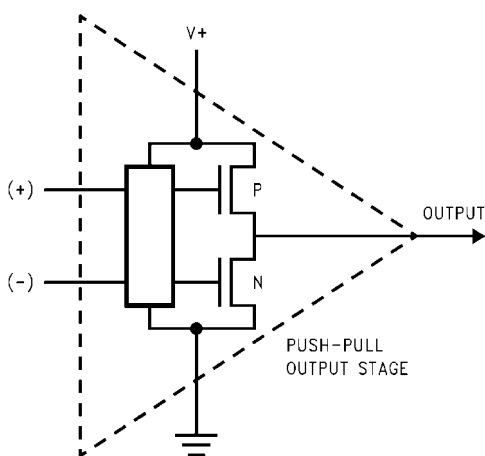

1285306

FIGURE 3.

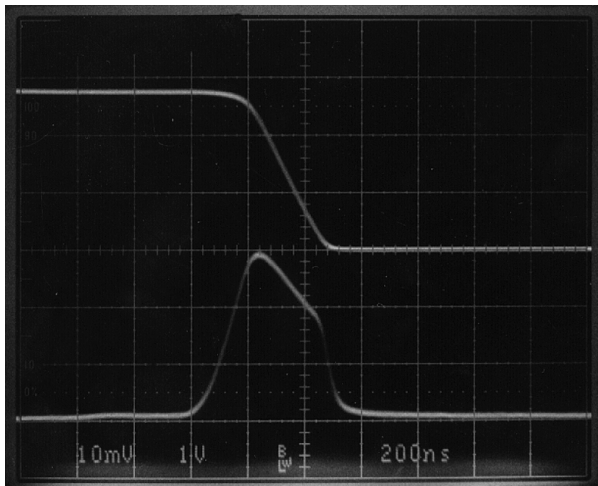

1285307

FIGURE 4. $R_S = 100\Omega$

The LMC7215 produces a small current spike of 300 μA peak for about 400 ns with 2.7V supply and 1.8 mA peak for 400 ns with a 5V supply. This spike only occurs when the output is going from high to low. It does not occur when going from low to high. [Figure 4](#) and [Figure 5](#) show what this current pulse looks like on 2.7V and 5V supplies. The upper trace is the output voltage and the lower trace is the supply current as measured with the circuit in [Figure 6](#).

If the power supply has a very high impedance, a bypass capacitor of 0.01 μF should be more than enough to minimize the effects of this small current pulse.

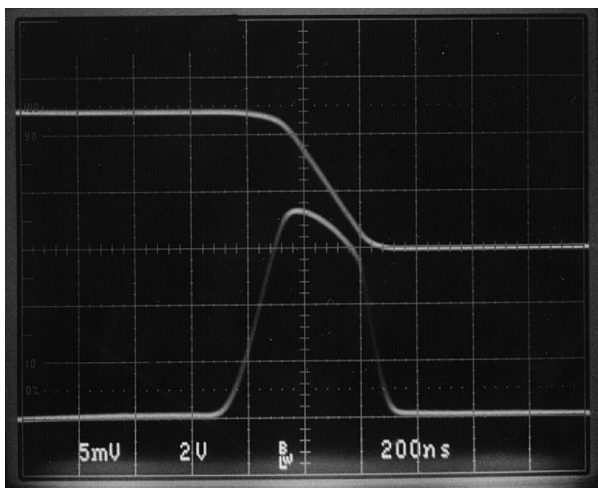

1285308

FIGURE 5. $R_S = 10\Omega$

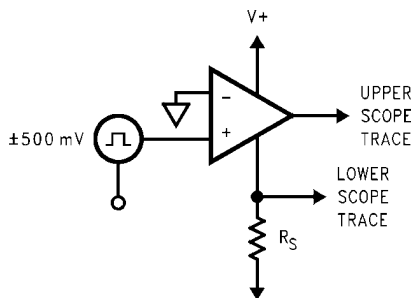

1285309

FIGURE 6.

LATCH-UP

In the past, most CMOS IC's were susceptible to a damaging phenomena known as latch-up. This occurred when an ESD current spike or other large signal was applied to any of the pins of an IC. The LMC7215 and LMC7225 both are designed to make them highly resistant to this type of damage. They have passed qualification tests with input currents on any lead up to 300 mA at temperatures up to 125°C.

SPICE MODELS

For a SPICE model of the LMC7215, LMC7225 and many other op amps and comparators, contact the NSC Customer Response Center at 800-272-9959 or on the World Wide Web at <http://www.national.com/models/index.html>.

Ordering Information

Package	Part Number	Package Marking	Transport Media	NSC Drawing
8-Pin SOIC	LMC7215IM	LMC7215IM	95 Units/Rail	M08A
	LMC7215IMX		2.5k Units Tape and Reel	
5-Pin SOT23	LMC7215IM5	C02B	1k Units Tape and Reel	MF05A
	LMC7215IM5X		3k Units Tape and Reel	
	LMC7215Q1IM5	C02Q	1k Units Tape and Reel	MF05A
	LMC7215Q1IM5X		3k Units Tape and Reel	
5-Pin SOT23	LMC7225IM5	C03B	1k Units Tape and Reel	MF05A
	LMC7225IM5X		3k Units Tape and Reel	

Automotive Grade (Q) product incorporates enhanced manufacturing and support processes for the automotive market, including defect detection methodologies. Reliability qualification is compliant with the requirements and temperature grades defined in the AEC-Q100 standard. Automotive Grade products are identified with the letter Q. PPAP (Production Part Approval Process) documentation of the device technology, process and qualification is available from Texas Instruments upon request.

SOT-23-5 Tape and Reel Specification

REEL DIMENSIONS

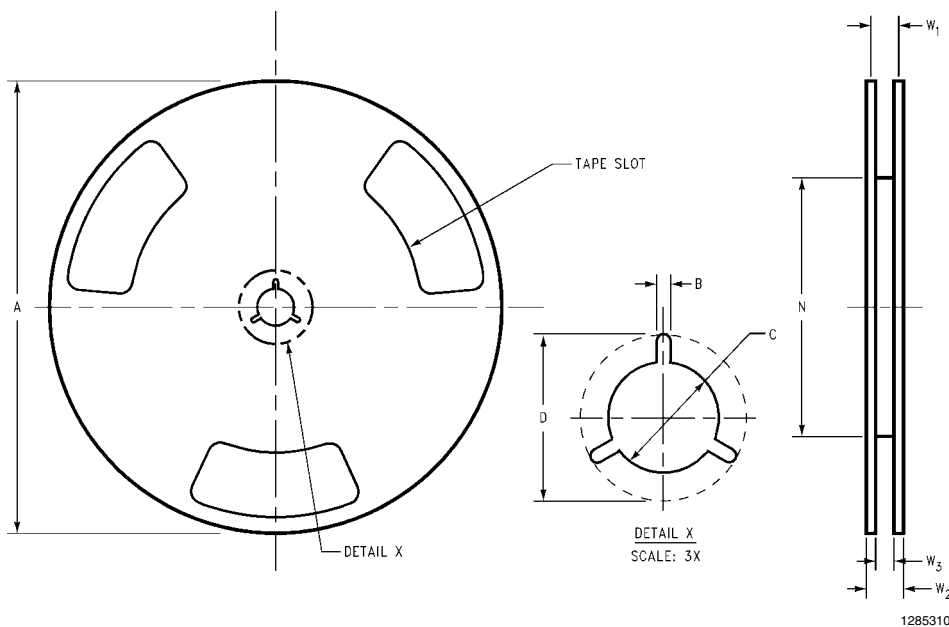

8 mm	7.00	0.059	0.512	0.795	2.165	0.331 + 0.059/-0.000	0.567	W1 + 0.078/-0.039
	330.00	1.50	13.00	20.20	55.00	8.40 + 1.50/-0.00	14.40	W1 + 2.00/-1.00
Tape Size	A	B	C	D	N	W1	W2	W3

TAPE FORMAT

Tape Section	# Cavities	Cavity Status	Cover Tape Status
Leader (Start End)	0 (min)	Empty	Sealed
	75 (min)	Empty	Sealed
Carrier	3000	Filled	Sealed
	1000	Filled	Sealed
Trailer (Hub End)	125 (min)	Empty	Sealed
	0 (min)	Empty	Sealed

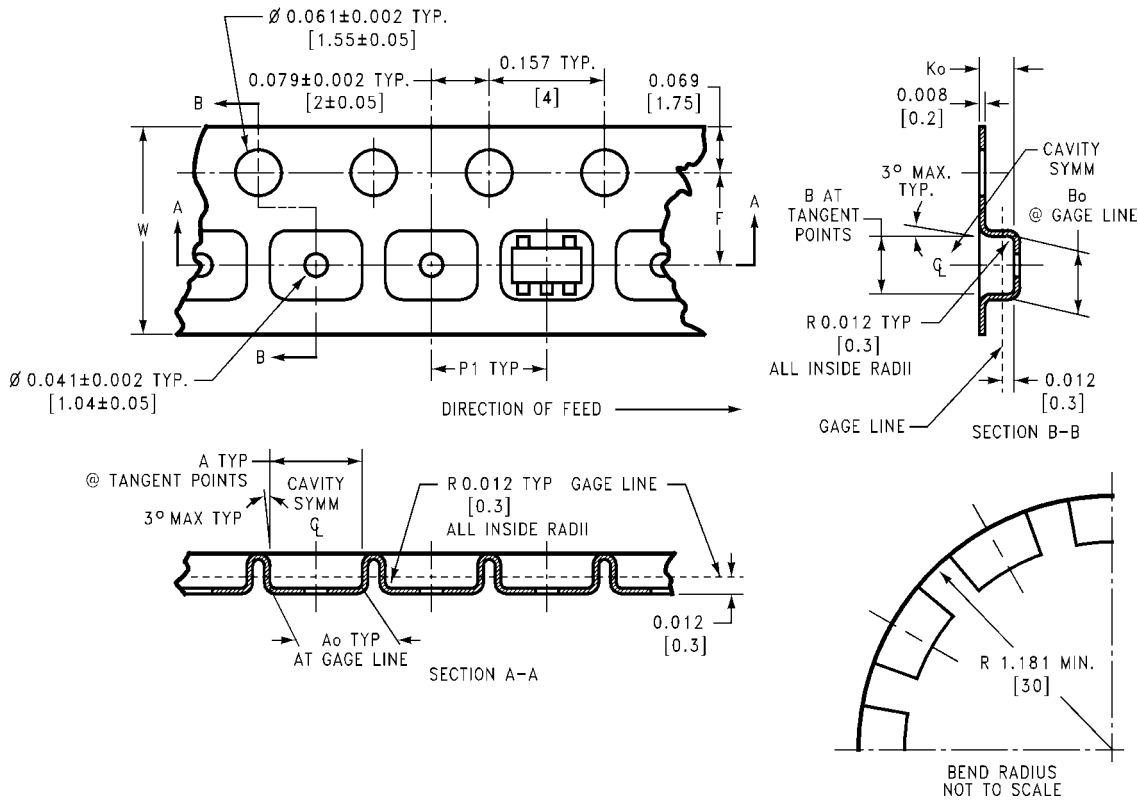
TAPE DIMENSIONS

1285311

8 mm	0.130 (3.3)	0.124 (3.15)	0.130 (3.3)	0.126 (3.2)	0.138 ± 0.002 (3.5 ± 0.05)	0.055 ± 0.004 (1.4 ± 0.11)	0.157 (4)	0.315 ± 0.012 (8 ± 0.3)
Tape Size	DIM A	DIM A ₀	DIM B	DIM B ₀	DIM F	DIM K ₀	DIM P1	DIM W

Physical Dimensions inches (millimeters) unless otherwise noted

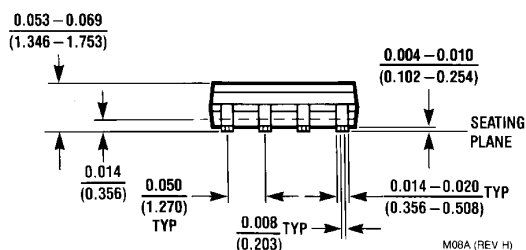
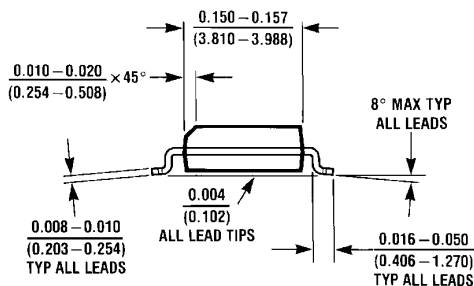
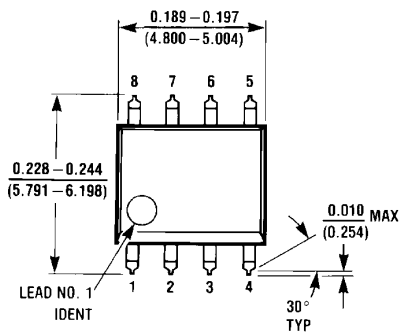

8-Pin SOIC
NS Package Number M08A

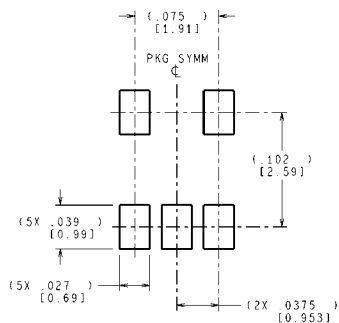
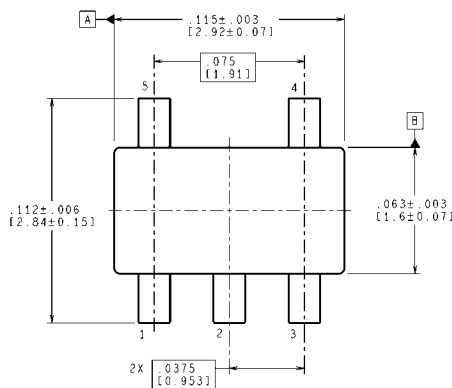

LAND PATTERN RECOMMENDATION

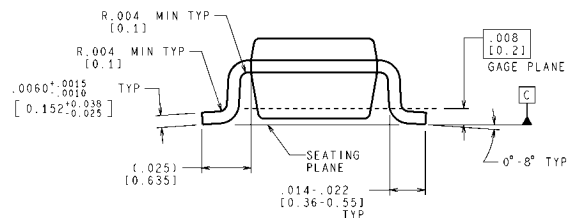
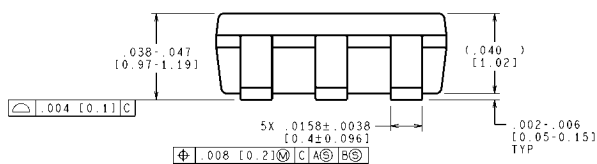

CONTROLLING DIMENSION IS INCH
VALUES IN [] ARE MILLIMETERS
DIMENSIONS IN () FOR REFERENCE ONLY

5-Pin SOT23
NS Package Number MF05A

MF05A (Rev D)

Notes

Notes

IMPORTANT NOTICE

Texas Instruments Incorporated and its subsidiaries (TI) reserve the right to make corrections, enhancements, improvements and other changes to its semiconductor products and services per JESD46, latest issue, and to discontinue any product or service per JESD48, latest issue. Buyers should obtain the latest relevant information before placing orders and should verify that such information is current and complete. All semiconductor products (also referred to herein as "components") are sold subject to TI's terms and conditions of sale supplied at the time of order acknowledgment.

TI warrants performance of its components to the specifications applicable at the time of sale, in accordance with the warranty in TI's terms and conditions of sale of semiconductor products. Testing and other quality control techniques are used to the extent TI deems necessary to support this warranty. Except where mandated by applicable law, testing of all parameters of each component is not necessarily performed.

TI assumes no liability for applications assistance or the design of Buyers' products. Buyers are responsible for their products and applications using TI components. To minimize the risks associated with Buyers' products and applications, Buyers should provide adequate design and operating safeguards.

TI does not warrant or represent that any license, either express or implied, is granted under any patent right, copyright, mask work right, or other intellectual property right relating to any combination, machine, or process in which TI components or services are used. Information published by TI regarding third-party products or services does not constitute a license to use such products or services or a warranty or endorsement thereof. Use of such information may require a license from a third party under the patents or other intellectual property of the third party, or a license from TI under the patents or other intellectual property of TI.

Reproduction of significant portions of TI information in TI data books or data sheets is permissible only if reproduction is without alteration and is accompanied by all associated warranties, conditions, limitations, and notices. TI is not responsible or liable for such altered documentation. Information of third parties may be subject to additional restrictions.

Resale of TI components or services with statements different from or beyond the parameters stated by TI for that component or service voids all express and any implied warranties for the associated TI component or service and is an unfair and deceptive business practice. TI is not responsible or liable for any such statements.

Buyer acknowledges and agrees that it is solely responsible for compliance with all legal, regulatory and safety-related requirements concerning its products, and any use of TI components in its applications, notwithstanding any applications-related information or support that may be provided by TI. Buyer represents and agrees that it has all the necessary expertise to create and implement safeguards which anticipate dangerous consequences of failures, monitor failures and their consequences, lessen the likelihood of failures that might cause harm and take appropriate remedial actions. Buyer will fully indemnify TI and its representatives against any damages arising out of the use of any TI components in safety-critical applications.

In some cases, TI components may be promoted specifically to facilitate safety-related applications. With such components, TI's goal is to help enable customers to design and create their own end-product solutions that meet applicable functional safety standards and requirements. Nonetheless, such components are subject to these terms.

No TI components are authorized for use in FDA Class III (or similar life-critical medical equipment) unless authorized officers of the parties have executed a special agreement specifically governing such use.

Only those TI components which TI has specifically designated as military grade or "enhanced plastic" are designed and intended for use in military/aerospace applications or environments. Buyer acknowledges and agrees that any military or aerospace use of TI components which have **not** been so designated is solely at the Buyer's risk, and that Buyer is solely responsible for compliance with all legal and regulatory requirements in connection with such use.

TI has specifically designated certain components which meet ISO/TS16949 requirements, mainly for automotive use. Components which have not been so designated are neither designed nor intended for automotive use; and TI will not be responsible for any failure of such components to meet such requirements.

Products

Audio	www.ti.com/audio
Amplifiers	amplifier.ti.com
Data Converters	dataconverter.ti.com
DLP® Products	www.dlp.com
DSP	dsp.ti.com
Clocks and Timers	www.ti.com/clocks
Interface	interface.ti.com
Logic	logic.ti.com
Power Mgmt	power.ti.com
Microcontrollers	microcontroller.ti.com
RFID	www.ti-rfid.com
OMAP Applications Processors	www.ti.com/omap
Wireless Connectivity	www.ti.com/wirelessconnectivity

Applications

Automotive and Transportation	www.ti.com/automotive
Communications and Telecom	www.ti.com/communications
Computers and Peripherals	www.ti.com/computers
Consumer Electronics	www.ti.com/consumer-apps
Energy and Lighting	www.ti.com/energy
Industrial	www.ti.com/industrial
Medical	www.ti.com/medical
Security	www.ti.com/security
Space, Avionics and Defense	www.ti.com/space-avionics-defense
Video and Imaging	www.ti.com/video

TI E2E Community

e2e.ti.com